

No power like it.

Black Bruin MR rotator

MR rotator is the best choice for heavy professional use, where high torque and precise operation are required. Due to reliability and suitability for different crane applications, MR rotators have become true classics for forest machines and truck cranes.



■ Proven in various crane applications.

www.blackbruin.com

**Black
Bruin**
No power like it.



Features and benefits

- axial piston construction guarantees even torque, durability and precise working
- designed to endure the high external loads
- the double-acting pressure relief valve prevents pressure peaks
- easy to fit to any crane equipment
- can be equipped with a swing damper (standard, light, hydraulic)

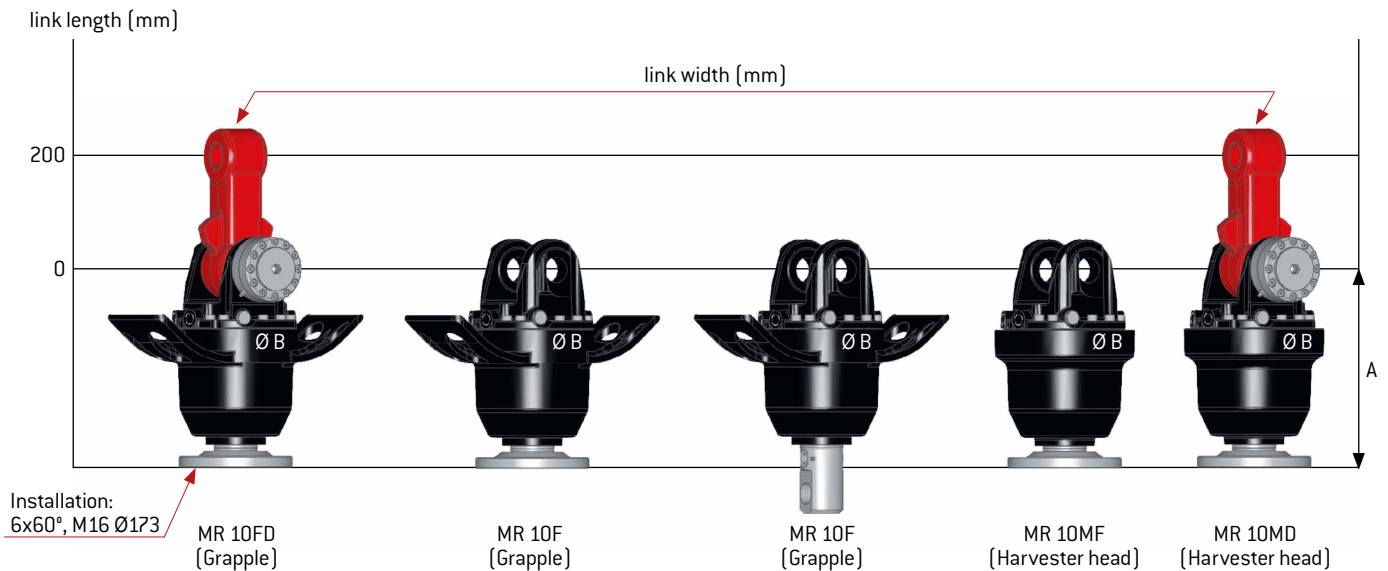

MODEL	PART NUMBER	BRAKE OPTIONS			WORKING PRESSURE INLETS	OIL FEEDTHROUGH FOR GRAPPLE OR TOOL	LINK LENGTH (mm)	LINK WIDTH (mm)	LINK PIN (mm)	A (mm)	B (mm)	WEIGHT (kg)
		Std. ¹⁾	Light ¹⁾	Hydraulic ²⁾								
MR 8AF	277 020 2305	N/A	N/A	N/A	Upper	YES	–	–	35	336	223	59
MR 10F	277 020 2605	“	“	“	“	“	–	–	45	352	“	63
MR 10FD	277 020 3605	Available	1	Available	“	“	200	80	“	“	“	84
MR 10F	277 020 3805	“	“	“	“	“	–	–	“	“	“	63
MR 10MF	277 020 2705	“	“	“	Upper and lower	NO	–	–	“	“	252	64
MR 10MD	277 020 3905	1	Available	Available	“	“	200	80	“	“	“	84

Max. working pressure: 250 bar/25 MPa, Max. torque: 2000 Nm, Max. axial load: 80 kN (MR 8) and 100 kN (MR 10). Inlets: R1/2".

1) spring operated brake, 2) pressure operated brake. For additional models and options, please contact sales at Sampo Hydraulics Ltd.

bb_MR_brochure_EN_500_2012-08-17

www.blackbruin.com



**Black
Bruin**
No power like it.